

NOTES:

1. REMOVE ALL LEAD AND OTHER FLASHING.
2. TEMPERATURE OF PIPE MUST NOT EXCEED 120° F (49° C).
3. PIPE SEAL MUST HAVE INTACT RIB AT TOP EDGE, REGARDLESS OF PIPE DIAMETER.
4. INSTALL A SECTION OF THE FLEX TPO PLUS REINFORCED MEMBRANE OVER SPLICE INTERSECTIONS PRIOR TO INSTALLING PRE-MOLDED PIPE FLASHING.

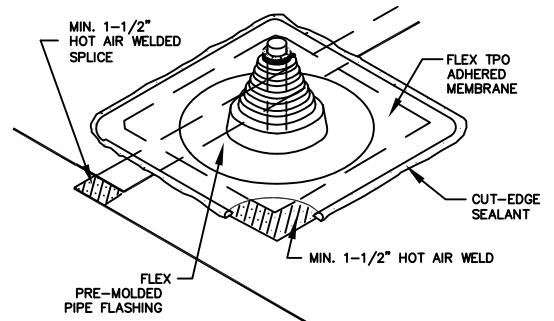

TPO 4.03  
FLEX PRE-FORMED BOOT